

# IEC62439 Driver

## High Availability Industrial Ethernet

### Key Features

- Fully compliant to IEC62439 Standard (IEC62439-3:2011, PRP)
- Bumpless redundancy (zero packet loss in case of failure)
- Works with off-the shelf networking equipment
- Does not rely on higher layer protocols to operate or be configured
- Driver is available for 32- and 64-bit Windows Systems, Linux and VxWorks
- Supervision via SNMP
- Management Application
- Windows Installer

### Typical Applications

- Ethernet based automation networks
- Robot control
- Synchronized drives
- Substation automation networks based on IEC 61850
- SCADA Systems with high availability requirements
- Hard real-time redundant Ethernet networks
- Industrial Ethernet without hardware redundancy such as EtherNet/IP and Modbus/TCP

## IEC62439 PRP Driver

**In automation networks, availability is a key requirement. Even a short outage can lead to disastrous consequences. The Parallel Redundancy Protocol (PRP) addresses this demanding requirement by communicating via two completely independent networks.**

Ethernet gains momentum in the industry and conquers new markets such as automation systems, power plants, traffic infrastructure, and SCADA systems. This increases the requirements on the availability of the network. An industry standard that addresses these requirements is the Parallel Redundancy Protocol (PRP).

PRP is based on a completely redundant network. Devices provide two network interfaces, each connecting to a different network. Both networks are completely independent. This approach provides a bumpless redundancy with off-the shelf networking equipment.

In a PRP network, any single network component may fail without losing a single Ethernet packet!

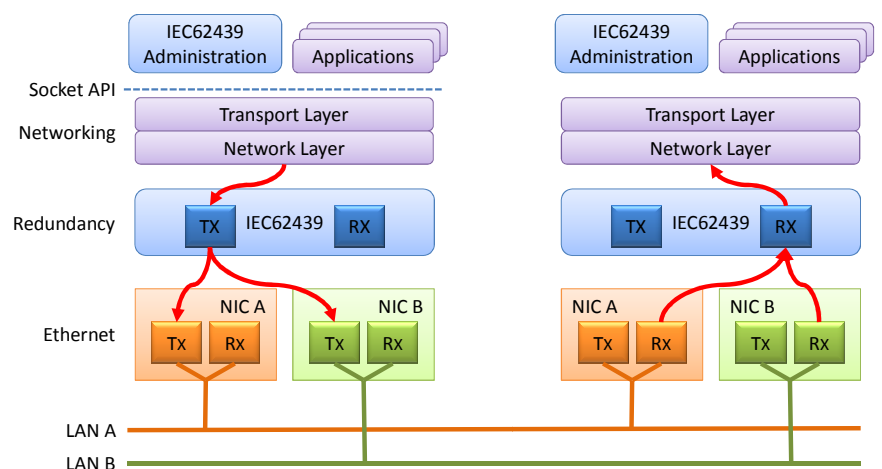

NetModule provides field proven IEC62439 drivers for all major operating systems. Please contact us if your system is not on the list of supported systems.

Features													
<b>IEC62439</b>	Fully compliant to the latest IEC draft Standard IEC62439-3:2011 PRP.												
<b>Zero switch-over time</b>	PRP sends Ethernet packets onto two independent networks and the receiver discards duplicate packets. No switch-over or reconfiguration is required in case of failure of a network component (switch, cabling, network interface card). This guarantees bumpless redundancy i.e. not a single packet is lost.												
<b>Transparent</b>	PRP is fully transparent to the applications. All applications running on Ethernet work seamlessly with PRP without modification or additional configuration. PRP is also transparent to other redundancy mechanisms such as RSTP and MRP.												
<b>7x24</b>	PRP networks support on-the-fly replacement of network infrastructure (cabling, switches) without disruption. This is a major advantage when 7x24 availability is required.												
<b>Flexible topology</b>	Supports different methods to attach a host: <table border="0" style="width: 100%; border-collapse: collapse;"> <tr> <td style="width: 15%; vertical-align: top;">DAN</td> <td style="width: 35%; vertical-align: top;">Doubly Attached Node</td> <td style="width: 50%; vertical-align: top;">High available nodes are attached to both redundant networks via two separate network interfaces.</td> </tr> <tr> <td style="vertical-align: top;">SAN</td> <td style="vertical-align: top;">Singly Attached Node</td> <td style="vertical-align: top;">Standard node without RRP functionality connected to one of the redundant networks (e.g. packet sniffer).</td> </tr> <tr> <td style="vertical-align: top;">VDAN</td> <td style="vertical-align: top;">Virtual Doubly Attached Node</td> <td style="vertical-align: top;">SAN as visible through a RedBox.</td> </tr> <tr> <td style="vertical-align: top;">RedBox</td> <td style="vertical-align: top;">Redundancy Box</td> <td style="vertical-align: top;">Connects SANs to both redundant networks.</td> </tr> </table>	DAN	Doubly Attached Node	High available nodes are attached to both redundant networks via two separate network interfaces.	SAN	Singly Attached Node	Standard node without RRP functionality connected to one of the redundant networks (e.g. packet sniffer).	VDAN	Virtual Doubly Attached Node	SAN as visible through a RedBox.	RedBox	Redundancy Box	Connects SANs to both redundant networks.
DAN	Doubly Attached Node	High available nodes are attached to both redundant networks via two separate network interfaces.											
SAN	Singly Attached Node	Standard node without RRP functionality connected to one of the redundant networks (e.g. packet sniffer).											
VDAN	Virtual Doubly Attached Node	SAN as visible through a RedBox.											
RedBox	Redundancy Box	Connects SANs to both redundant networks.											
<b>Configuration</b>	System parameters can be configured using the intuitive, GUI based management application. Customization to your needs and branding are possible. It is thus possible to adapt the look & feel to your requirements.												
<b>Monitoring</b>	The network topology and the network links are constantly monitored using supervision frames. With SNMP, finding and replacing defect network components is made easy.												
<b>Operating Systems</b>	<table border="0" style="width: 100%; border-collapse: collapse;"> <tr> <td style="width: 15%;">Windows</td> <td style="width: 85%;">Supports 32- and 64bit versions of Windows XP, Windows 7 and Windows Server 2008.</td> </tr> <tr> <td>VxWorks</td> <td>Support for VxWorks 5.5.1, VxWorks 6.8 and VxWorks 6.9.</td> </tr> <tr> <td>Linux:</td> <td>Support for different distributions and kernel versions on request.</td> </tr> </table>	Windows	Supports 32- and 64bit versions of Windows XP, Windows 7 and Windows Server 2008.	VxWorks	Support for VxWorks 5.5.1, VxWorks 6.8 and VxWorks 6.9.	Linux:	Support for different distributions and kernel versions on request.						
Windows	Supports 32- and 64bit versions of Windows XP, Windows 7 and Windows Server 2008.												
VxWorks	Support for VxWorks 5.5.1, VxWorks 6.8 and VxWorks 6.9.												
Linux:	Support for different distributions and kernel versions on request.												

**NetModule AG**

 Meriedweg 11  
 3172 Niederwangen

 T +41 31 985 25 10  
 F +41 31 985 25 11

Switzerland

**NetModule GmbH**

 Frankfurter Strasse 92  
 65760 Eschborn  
[sales@netmodule.com](mailto:sales@netmodule.com)

 T +49 6196 77 99 79 0  
 F +49 6196 77 99 79 9  
[www.netmodule.com](http://www.netmodule.com)

Germany