



High Speed Communication Module Eval System

Key Features of the Evaluation System:

- High Speed Miniature Single Board Computer, SODIMM-200 Connector
- Freescale MPC8314 PowerPC CPU running at 400MHz
- Up to 512MB DDR2 RAM
- 1GB NAND Flash Memory
- 1 Gigabit Ethernet Interface
- 1 PCI Express Mini Card Slot
- 2 high speed USB Host Ports
- 2 RS-232 Interfaces
- Extension Interface (I2C, SPI, TDM, multiplexed Bus Interface)
- Single 12Vdc Supply

High Speed Communication Module Evaluation System

The NetModule High Speed Communication Module is a high performance Single Board Computer (SBC) module aimed for the rapid development of industrial controllers and networking equipment. The module is best suited for low to medium volume designs with critical time to market and demanding environmental requirements.

The Module is built around the Freescale MPC8314 controller. This power efficient CPU features suspend modes for low power consumption and a wide range of state-of-the-art interfaces.

The Evaluation System consist of the NetModule High Speed Communication Module, the Baseboard which supports the most important features of the CPU Module, either a VxWorks 6.x or a Linux 2.6x BSP and the necessary user documentation.

The Baseboard has a 10/100/1000Mbps twisted pair Interface, a PCI Express Mini Card Slot (including a SIM card interface for GSM / UMTS Modules), 2 high speed USB Host ports, 2 RS-232 ports and an extension port with I2C, SPI, TDM and a 16 bit multiplexed bus interface.

Typical Applications for the NetModule High Speed Communication Module

- High Speed Router/Gateway
- Headless Industrial Controller
- VoIP Gateway
- High Speed Wireless Access Point
- Firewall, VPN Appliance
- Network Attached Storage (NAS)
- Home Server

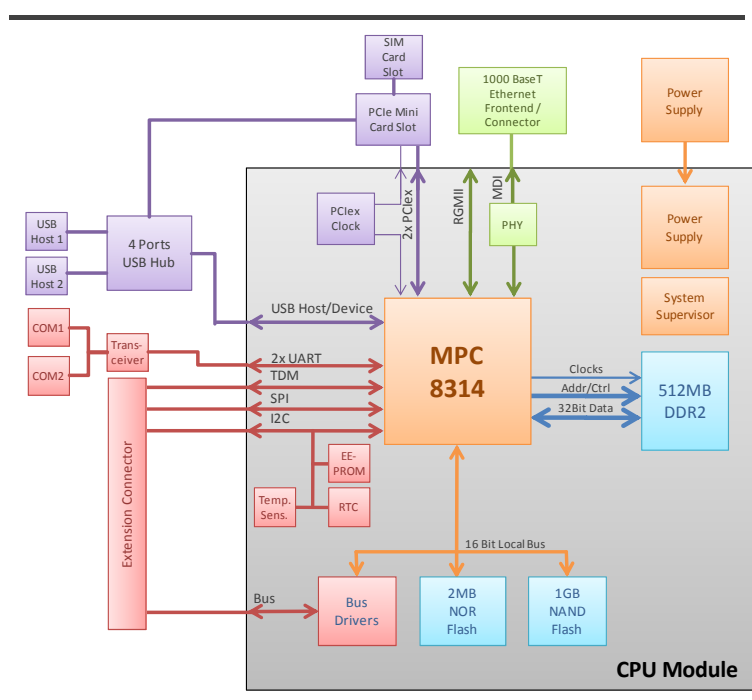

Features	
CPU	<p>Freescale MPC8314 CPU running at 400MHz. Superscalar, pipelined PowerPC RISC architecture with 2 integer and 1 floating point units. 16kB data and 16kB instruction cache with error checking & correction (ECC). Security engine for block encryption and public/private key computation.</p>
Memory	<p>512MB DDR2-266 memory, 32 Bit bus (default 256MB, optional 128MB). 128MB to 1GByte NAND Flash on 8 Bit bus. Hardware accelerated high speed access with ECC support. 512kBytes to 2MBytes NOR Flash for bootloader. 32kBit Serial EEPROM (higher capacity available upon request).</p>
Misc Peripherals	<p>Temperature sensor. Range -55°C to 125°C, resolution 0.5°C, alarm interrupt. I2C Real Time Clock with alarm function and battery backup.</p>
System Supervisor	<p>Dedicated microcontroller based System Supervisor. Power sequencing and voltage supervision on module. Window triggered watchdog for improved system reliability.</p>
Connectivity	<p>Twisted Pair Gigabit Ethernet (10/100/1000Mbps) with IEEE 1588 precision clock synchronization support. Standard PCI Express Mini Card Slot with SIM Card Interface for UMTS / GSM cards. 2 USB High Speed Host ports (480Mbps), Two 16450/16650 compatible UARTs with FIFO. Operation up to 460kBs supported. One full featured UART with hardware handshaking and additional control signals. One standard UART with hardware handshaking. Extension Interface: I2C bus at 100/400kHz SPI bus up to 33 MBps TDM highway with up to 128 channels Multiplexed address-/databus. Easily interfaces with standard peripherals or FPGA on mainboard. 16 Bit data bus and 18 Bit address bus. Two individually configurable chip selects. Synchronous or asynchronous mode possible.</p>
Debug Support	<p>JTAG Debugger Interface Generic LED and test point on CPU GPIO pins.</p>
Power Supply	<p>Single 12Vdc Power Supply Maximum power consumption of 7W</p>
Environmental	<p>Storage: -40°C to +100°C. Operation: 0°C to 40°C. Pb free, ROHS compliant.</p>
Operating Systems	<p>VxWorks 6.x, Linux 2.6.x, others available on request.</p>

NetModule AG

 Meriedweg 11
 3172 Niederwangen

 T +41 31 985 25 10
 F +41 31 985 25 11

Switzerland

NetModule GmbH

 Frankfurter Strasse 92
 65760 Eschborn

 T +49 6196 77 99 79 0
 F +49 6196 77 99 79 9

Germany

sales@netmodule.com
www.netmodule.com