

# 1. Outline Dimensions

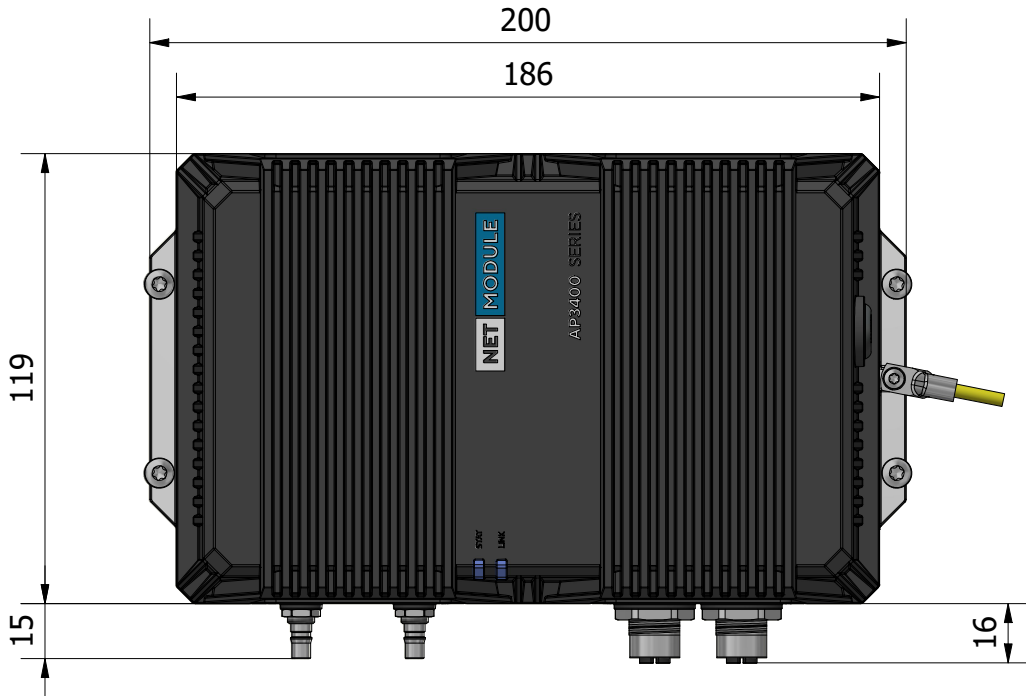
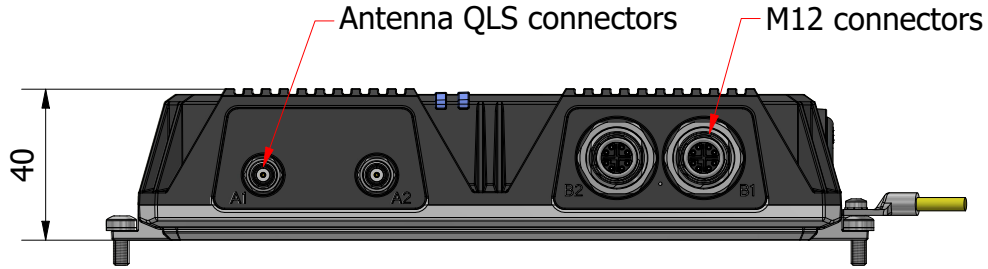

All dimensions in mm

Material	Oberflächenbeschichtung	Fläche N/A	Gezeichnet rk 08.12.2021	
Dimension		Gewicht N/A	Geprüft rr 05.01.2022	
Allgemeintoleranzen	Verwendung / Bezeichnung	Geändert rk 05.01.2022		
<b>NetModule AG</b> Phone: +41 (0)31 985 25 10 Fax: +41 (0)31 985 25 11 Maulbeerstrasse 10 CH-3011 Bern info@netmodule.ch www.netmodule.com	<b>AP3400-2Wax</b> Installation Instruction	Masstab A4	Blaft 1 / 6	
		Artikelnr / Zeichnungsnr <b>1001931</b>		Version <b>01</b>

## 2. Mounting Specification

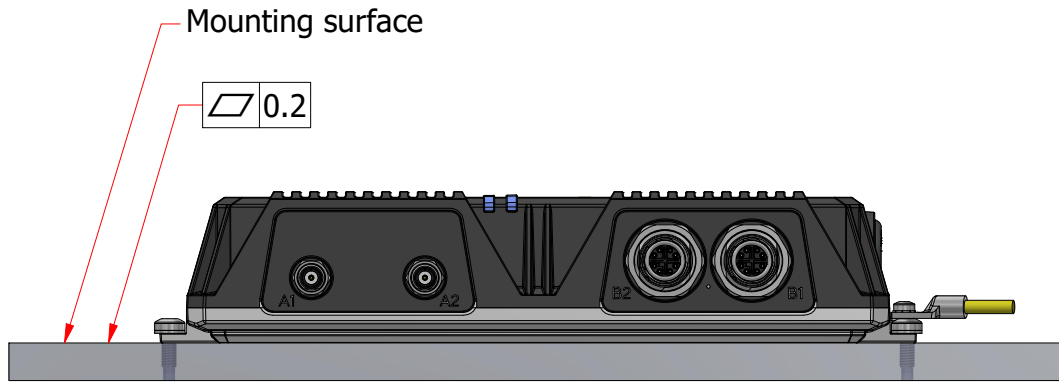

To optimise cooling of the device, allow air flow around it and mount it to a metal surface if possible.

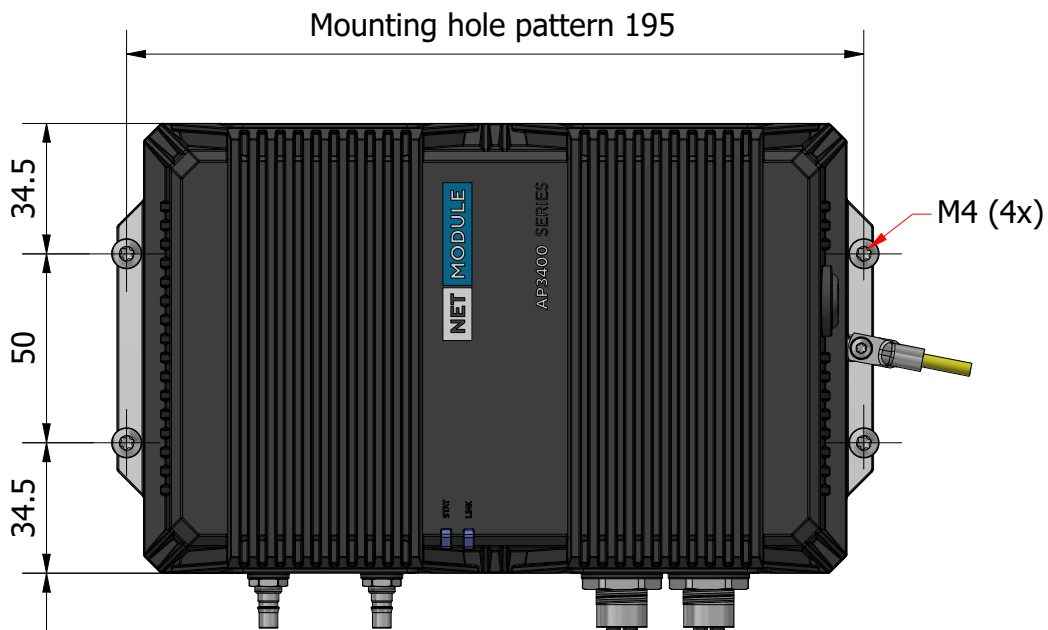

Recommendation: 110 mm space for cable mounting

Material	Oberflächenbeschichtung	Fläche N/A	Gezeichnet rk 08.12.2021
Dimension		Gewicht N/A	Geprüft rr 05.01.2022
Allgemeintoleranzen	Verwendung / Bezeichnung		Geändert rk 05.01.2022
<b>NetModule AG</b> Maulbeerstrasse 10 CH-3011 Bern Phone: +41 (0)31 985 25 10 Fax: +41 (0)31 985 25 11 info@netmodule.ch www.netmodule.com	<b>AP3400-2Wax</b> Installation Instruction	Massstab A4 	Blatt 2 / 6
		Artikelnr / Zeichnungsnr 1001931	Version 01

### 3. Device Mounting

3.1 Place the screw and lock washer over the mounting hole (Figure 2)

3.2 Tighten the screws | Drive type: Torx T20 | Torque: 2.5Nm (Figure 3)

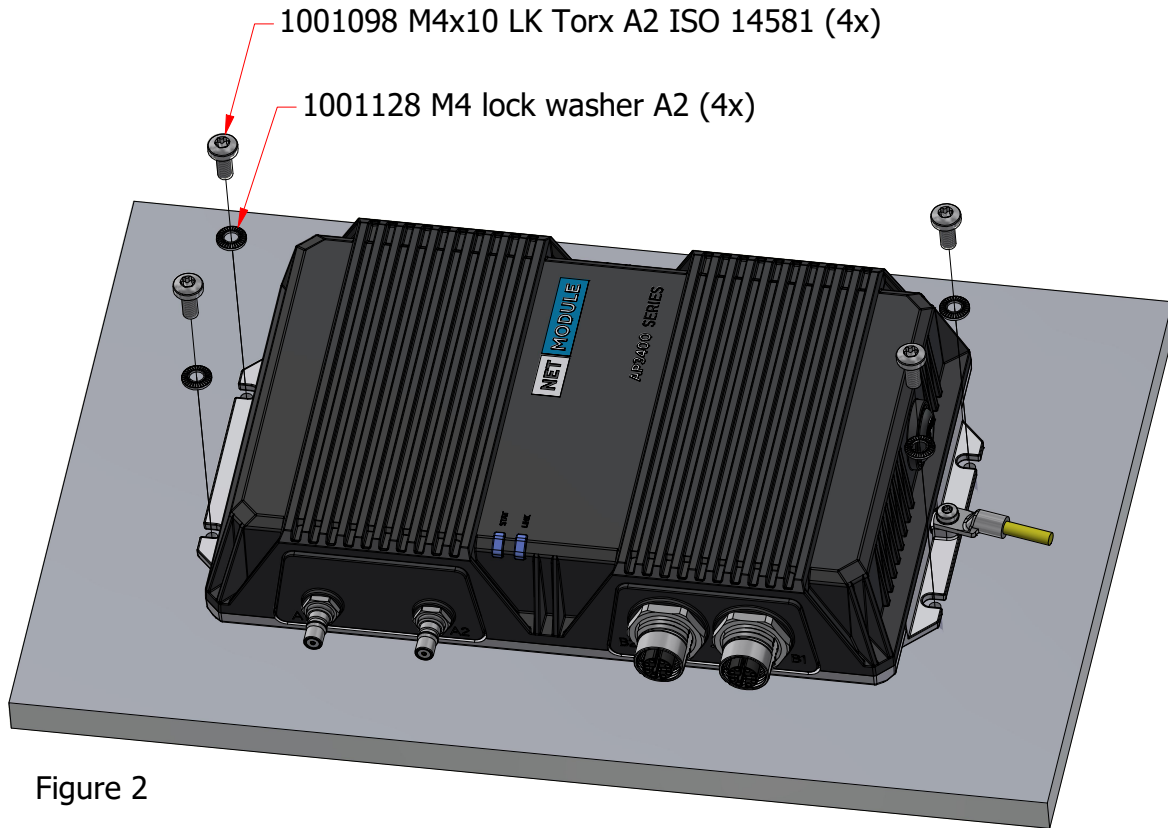

Figure 2

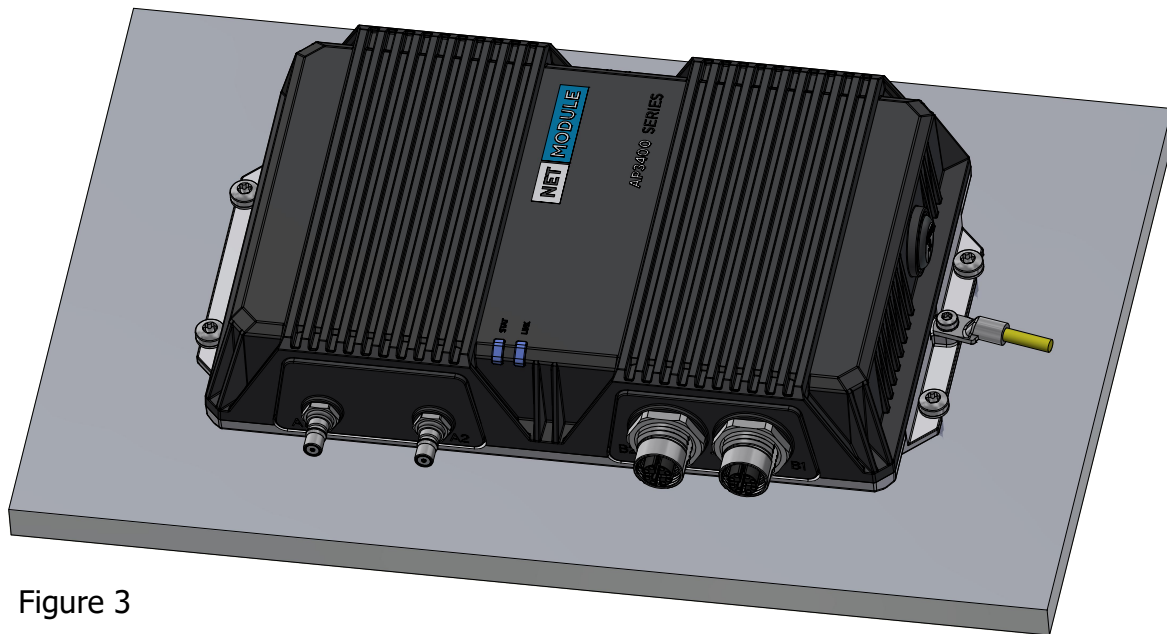

Figure 3

Material	Oberflächenbeschichtung	Fläche N/A	Gezeichnet <b>rk</b> 08.12.2021	
Dimension		Gewicht N/A	Geprüft <b>rr</b> 05.01.2022	
Allgemeintoleranzen	Verwendung / Bezeichnung		Geändert <b>rk</b> 05.01.2022	
<b>NetModule AG</b> Maulbeerstrasse 10 CH-3011 Bern Phone: +41 (0)31 985 25 10 Fax: +41 (0)31 985 25 11 info@netmodule.ch www.netmodule.com	<b>AP3400-2Wax</b> Installation Instruction	Massstab A4	Blatt 3 / 6	
		Artikelnr / Zeichnungsnr <b>1001931</b>		Version <b>01</b>

# 4. Earthing Cable Mounting

4.1 Place the screw, lock washer and cable lug over the mounting hole (Figure 4)

4.2 Tighten the screw | Drive type: Torx T10 | Torque: 1Nm (Figure 5)

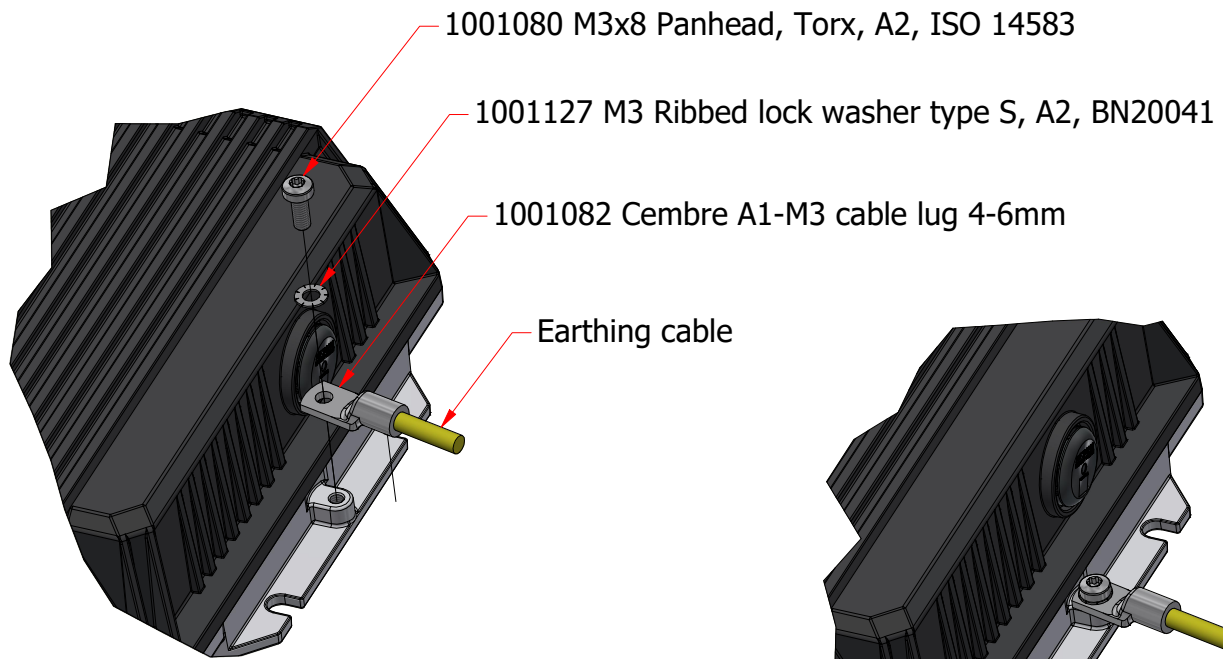

Figure 4

Figure 5

Material	Oberflächenbeschichtung	Fläche N/A	Gezeichnet <b>rk</b> 08.12.2021
Dimension		Gewicht N/A	Geprüft <b>rr</b> 05.01.2022
Allgemeintoleranzen	Verwendung / Bezeichnung		Geändert <b>rk</b> 05.01.2022
<b>NetModule AG</b> Phone: +41 (0)31 985 25 10 Fax: +41 (0)31 985 25 11 Maulbeerstrasse 10 CH-3011 Bern info@netmodule.ch www.netmodule.com	<b>AP3400-2Wax</b> <b>Installation Instruction</b>	Massstab A4 	Blatt <b>4 / 6</b>
<b>NET MODULE</b>		Artikelnr / Zeichnungsnr <b>1001931</b>	Version <b>01</b>

© NetModule AG. All rights reserved, also regarding any disposal, exploitation, reproduction, editing, distribution, as well as in the event of applications for industrial property rights.

# 5. Cable Mounting

- 5.1 Connect the cables according the port layout (Figure 6)
- 5.2 Recommended cable guideline (Figure 7)

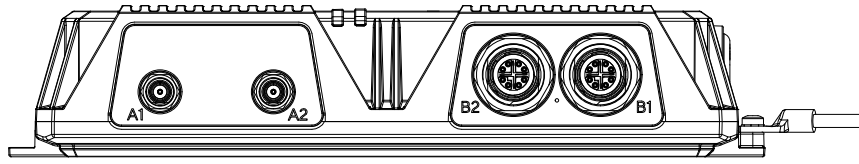

Port Layout 2x QLS		
Connector	Label	Application
QMA/QLS	A1	WIFI
QMA/QLS	A2	WIFI

Port Layout 2x M12		
Connector	Label	Application
M12	B1	ETH1 PoE
M12	B2	ETH2

Figure 6

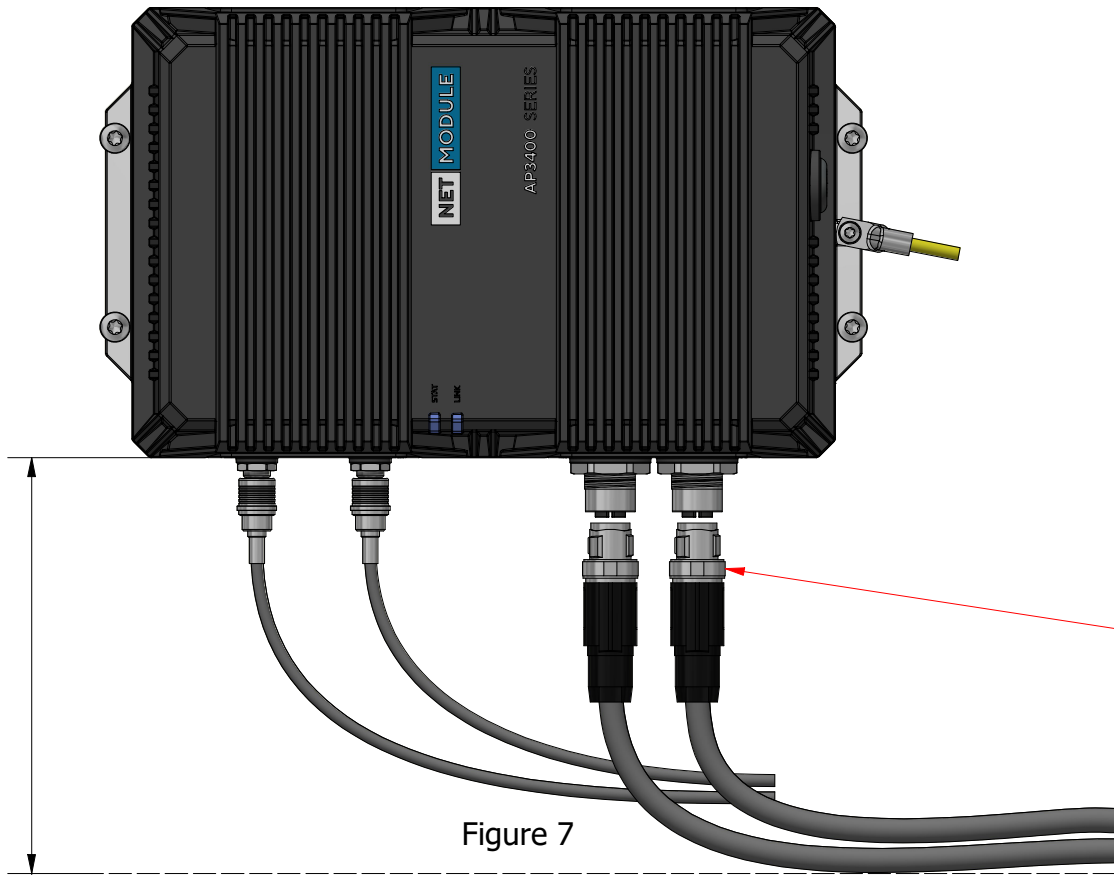

Figure 7

Recommendation: 110 mm space for cable mounting

Refer to cable specs for bending radius

If the mating connector does not have M12-knurls with SPEEDCON tighten the M12-knurls to 0.4 Nm (e.g. using Phoenix Contact SACC BIT M12-D20, 1208445 and with TSD 04 SAC, 1208429)

Material	Oberflächenbeschichtung	Fläche N/A	Gezeichnet rk 08.12.2021
Dimension		Gewicht N/A	Geprüft rr 05.01.2022
Allgemeintoleranzen	Verwendung / Bezeichnung		Geändert rk 05.01.2022
<b>NetModule AG</b> Phone: +41 (0)31 985 25 10 Fax: +41 (0)31 985 25 11 info@netmodule.ch www.netmodule.com Maulbeerstrasse 10 CH-3011 Bern	<b>AP3400-2Wax</b> <b>Installation Instruction</b>	Massstab	A4 5 / 6
		Artikelnr / Zeichnungsnr	Version
		1001931	01

# 6. Valid Device Mounting Positions

## 6.1 No mounting position restrictions

Horizontal mounting on x/y surface

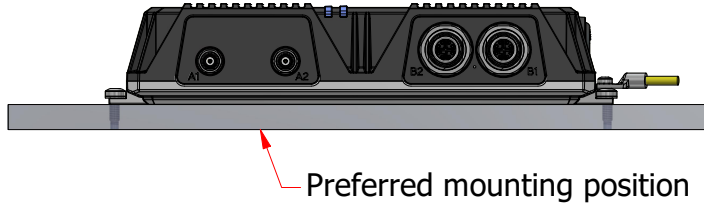

Vertical mounting on x/z surface



Horizontal mounting on x/y surface

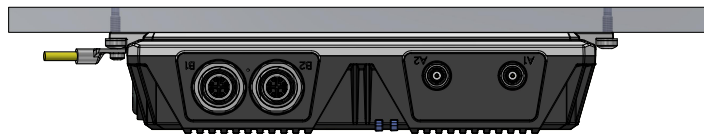

Material	Oberflächenbeschichtung	Fläche N/A	Gezeichnet <b>rk</b> 08.12.2021
Dimension		Gewicht N/A	Geprüft <b>rr</b> 05.01.2022
Allgemeintoleranzen	Verwendung / Bezeichnung	Geändert <b>rk</b> 05.01.2022	
<b>NetModule AG</b> Phone: +41 (0)31 985 25 10 Fax: +41 (0)31 985 25 11 info@netmodule.ch www.netmodule.com <b>NET MODULE</b>	<b>AP3400-2Wax</b> <b>Installation Instruction</b>	Massstab A4 Blatt 6 / 6	Artikelnr / Zeichnungsnr <b>1001931</b>
		Version <b>01</b>	

© NetModule AG. All rights reserved, also regarding any disposal, exploitation, reproduction, editing, distribution, as well as in the event of applications for industrial property rights.